



ATEX & IECEX

Components, equipment for hazardous areas
and potentially explosive atmospheres

EN



ATEX CATALOGUE: Rev. 00/2020

GIOVENZANA INTERNATIONAL B.V. reserves the right to modify, as specifications change, all technical and functional characteristics of the products shown in the catalogue without prior notice as this information is intended for general knowledge and is not legally binding. The most updated version of this catalogue is downloadable from the website www.giovenzana.com



ATEX & IECEx



THE PHILOSOPHY

Giovenzana's philosophy is based on the basic principles of company management, dynamism and continuous research of the operator's needs in the field of human-machine interaction. These principles, thanks to the experience and professionalism of their staff, guarantee development and growth.

THE HISTORY

A reality with great managerial abilities, over 65 years of history to its third generation, Giovenzana sets its growth:

- in the market analysis;
- in the diversification of production;
- investing in technology and collaboration of just your own staff.

THE PRODUCTS

Giovenzana, a leader in industrial technology, is today a reference point for the:

- Handling equipment;
- Automation system;
- Lift/Elevator equipment;
- ATEX & IECEx;
- Maintenance;
- Command and control of moving parts.

Study, design and production combine in a single objective to fully cover industrial needs.

QUALITY AS A LIFESTYLE

Giovenzana is an **UNI EN ISO 9001:2015** certified company.

The commercial success of a product is the result of a joint commitment of human resources, programmed daily in the procedures that contribute to form a quality organizational system.

Giovenzana's company is also certificated **UNI EN ISO 14001:2015** because the task of a company, today, is not only that of "making a good product" but also to implement logic of sustainable development for the protection of the environment within its production processes.

THE PRODUCTION

The solutions proposed are the result of a careful examination of the requirements of industrial components, in full compliance with international safety standards.

There are four product sectors: industrial automation, lift/elevator technology, handling system and ATEX & IECEx.

AUTOMATION

Includes Phoenix series cam switches with capacities from 12A to 200A; Regolus series switches with capacities from 16A to 160A; Pegasus, Orion and NEMA series auxiliary controls; thermoplastic and pre-wired limit switches; foot switches and micro switches.

LIFT/ELEVATOR

Throughout the years, continuous technological research and development has made Giovenzana the undisputed leader in its field. The range includes maintenance stations for car top, under car devices and pit bottom controls fully in compliance with the new international standards' requirements.

HANDLING SYSTEM

Handling equipment comprises of single and double row pendant stations up to 14 gang for control and direct switching, position and rotary gear limit switches, slip rings, warning horns, busbar conductor rails and festoon system.

ATEX & IECEx

Giovenzana has obtained all the certifications of ATEX and IECEx company system (QAN and QAR) for the potentially Explosion Atmospheres. ATEX is the European Directive mandatory in conformity with the international standard EN 60079 - IEC 60079. Giovenzana develops, implements projects and builds safety systems and solutions, equipment and components. The aim is to protect people and the environment through the safety of components, systems and equipment.

Our catalogue of explosion-proof products (for zone 1-2, 21-22 Gas and Dust) is constantly being developed thanks to our R&D engineering department.

- Regolus Ex series **switch disconnectors** with capacities from 25A to 100A;
- Regolus Ex series **enclosures** with a wide temperature range: -60° C ... +150° C;
- FGR2-Ex series **limit switches**;
- MFI-Ex series **micro switches**;
- Phoenix Ex series **cam switches** with capacities from 12A to 40A;
- Ex series **festoon system**.

CERTIFIED PRODUCTION

Product certification:

EC-Type Examination Certificate

Production and quality certifications:

1. Quality Assurance notification (QAN) required for ATEX
2. Quality Assessment Report (QAR) required for IECEx

The manufacturer is required to implement a production and quality system in accordance with ISO/IEC 80079-34. This system involves extraordinary safety measures and is regularly monitored and approved by the reporting bodies through verification inspections. With these two important certificates Giovenzana has obtained the authority to design, develop, implement, and construct equipment and components for security systems solutions.



Our goal is to protect people and the environment thanks to the safety of our systems and products.

The **ATEX** mark (**EX**plosive **AT**mospheres) refers to the European directive on the risk of deflagration in potentially explosive atmospheres.

ATEX 2014/34/EU

It concerns the requirements for electrical and non-electrical equipment used in potentially explosive environments. According to this directive, the producer must comply with the requirements and mark the articles in accordance with the particular categories.

This Directive lays down requirements for the safety and health protection of people, animals and property and includes several procedures for demonstrating that equipment complies with the requirements of the Directive.

HAZARDOUS AREAS' CLASSIFICATION

A potentially explosive atmosphere is an atmosphere that could become explosive according to the local conditions of work (environments with a presence of air and flammable substances in the form of gas, smog, steams and dusts).

The ATEX Directive defines two types of explosive atmosphere:

- Atmospheres with explosive gases:
zone 0, 1 and 2;
- Atmospheres with explosive dusts:
zone 20, 21 and 22.

Atmospheres with explosive gases

Zone 0: an area in which an explosive atmosphere consisting of a mixture of air and flammable substances in the form of gas, vapour or mist is present continuously or for long periods of time.

Zone 1: an area in which an explosive atmosphere consisting of a mixture of air and flammable substances in the form of gas, vapour or mist, is likely to occur during normal operation.

Zone 2: an area in which an explosive atmosphere consisting of a mixture of air and flammable substances in the form of gas, vapour or mist, is not likely to occur during normal operations, but if it does, it will only persist for a short period.

Atmospheres with explosive dusts

Zone 20: an area in which an explosive atmosphere in the form of a cloud of combustible dust in the air is present continuously, often or for long periods.

Zone 21: an area in which the explosive atmosphere, in the form of a cloud of

combustible dust in the air, is likely to occur during normal operations.

Zone 22: an area in which an the explosive atmosphere, in the form of a cloud of combustible dust in the air, is probably not present during normal operations but, if it does, persists only for a short time.



IECEX

The IECEX Certification facilitates the international exchange and acceptance of test results for safety products between laboratories for national approval or certification in one or more participating countries without the need for further tests shall be carried out.

The IECEX Certification system is approved by the United Nations and is internationally recognised as the certified system to promote the safety of the services offered and the personnel associated with the devices, systems and systems used in explosive atmospheres.

INTERNATIONAL CLASSIFICATIONS

Some countries, while recognising IECEX certification as a standard for testing, require additional local certification for marking and purchasing equipment such as: INMETRO for the Brazilian market and EAC for products in Russia and Ukraine. Our products are in conformity with EAC TR TS 012/2011 "Safety components and equipment for hazardous areas and potentially explosive atmospheres".



ATEX DIRECTIVE APPLIED TO INDUSTRIAL PRODUCTION

The ATEX Directive is applicable in many sectors of industrial production. The following are the production sectors and companies involved in the ATEX directive and the risks that it has the duty to regulate thanks to the purchase of equipment and certified components.

SECTOR A: food and agriculture (Dust)

SECTOR B: fixtures, fittings and metal industries (Dust)

SECTOR C: aviation, aerospace, naval, automotive, railways (Dust)

SECTOR D: chemistry (Dust - Gas)

SECTOR E: combustibles, fuel, energy, metallurgy (Dust - Gas)

SECTOR F: research, universities and laboratories (Dust - Gas)

SECTOR G: furniture, carpentry, leather processing, tanneries, textiles (Dust)

SECTOR H: plastics and rubber (Dust)

SECTOR I: explosive waste disposal (Dust - Gas)

SECTOR L: paper mills (Dust)



SECTOR B: FIXTURES, FITTINGS AND METAL INDUSTRIES (Dust)

// COMPANIES

Metal fixtures, metal fittings for fixtures, fine profiling, metal surface processing.

// HAZARDOUS AREAS

Potentially explosive atmosphere due to the presence of fine metal powders caused by production processes. Presence on the walls, over time, of micro powders and accumulation in interstices and in the automatic machinery. Smoothing powders. In the production of moulded metal parts, explosive metal powders can be formed during surface treatment (grinding). This is particularly true in the case of light metals and alloys mixtures. These metal powders can cause an explosion risk in separators and filters. Conductive dusts are the most dangerous.

// MATERIALS

Active ingredients, various chemical components, pharmaceutical products, Bio Hazard.



SECTOR A: FOOD AND AGRICULTURE (Dust)

// COMPANIES

Mills, biscuits, pasta, semolina and sugar factories; plants and machines for food processes, roasting coffee, grinding cereals and cocoa, bakeries, distilleries.

// HAZARDOUS AREAS

The typical working of the food industry involves the handling of materials stored in silos with consequent emission into the environment of dusts and potentially explosive zones. Explosive dusts may form during transport and storage of cereals. Drying, grinding and refining of agro-food materials creates an explosion risk. Alcoholic substances are often used in the food industry to sterilise controlled environments.

// MATERIALS

Cocoa, coffee, cereals (mixed powders), wheat flour, soya flour, gelatine, wheat, milk powder, lactose, rye, whey, sugar, granulated sugar, alcohol.



SECTOR C: AVIATION, AEROSPACE, NAVAL, AUTOMOTIVE, RAILWAYS (Dust)

// COMPANIES

Aircraft construction, trains, cars maintenance, precision mechanics, aerospace electronics, paint booths, resin processing.

// HAZARDOUS AREAS

Presences of micro powders in the processing of Hi-Tech components. Machining of aircraft cockpit. Powders produced by vibration tests on electronic components. Propelling treatment in the aerospace industry. Suction of fuel from the tank. Aircraft maintenance procedures. Residues from engines of explosive material. Construction of wooden boats, resin and the presence of explosive fumes. Operations in the engine room and recycling of hydrocarbons.

// MATERIALS

Hydrocarbons, propellants, sanding metal powders, fuels, solvents, magnesium, zirconium, aluminum.



// MATERIALS

Hydrocarbons, LPG, refinery gas, fuels, metal powders, acids, hard coal, pellets.



**SECTOR F:
RESEARCH, UNIVERSITIES AND LABORATORIES (Dust - Gas)**

// COMPANIES

Oxygen cylinders, test benches or analysis.

// HAZARDOUS AREAS

Storage area for oxygen cylinders or flammable gases. Presences of micro powders in the processing of Hi-Tech components. Use of solvents in laboratory tests. The chambers are sterilized using ethanol or flammable solvents.

// MATERIALS

Various solvents, ethanol, alcohol, gas cylinders, oxygen, laboratory products, micro electronic powder, resins, gallium arsenide, photocell production, powders from electrical circuits, arsin.

**SECTOR D:
CHEMISTRY (Dust - Gas)**

// COMPANIES

Paints, colours, soda, alcohol, chemicals, solvents, oils.

// HAZARDOUS AREAS

Presence of solvents and fumes during the production cycle. Production of hydrogen in chemical reactions. Processing of solid, liquid and gaseous materials with consequent risk of creating explosive atmospheres. Use of dusts or liquids explosives for product synthesis. Various solvents: acetate, acetylene, acetone, alcohol, ethylene, etc.

// MATERIALS

Chemicals in the process.



**SECTOR E:
COMBUSTIBLES, FUEL, ENERGY,
METALLURGY (Dust - Gas)**

// COMPANIES

Refining plants, gas stations, gas processing plants such as gas oil and methane, metallurgy, electricity generation.

// HAZARDOUS AREAS

Accidental losses and spillage operations. The hydrocarbons treated in the refineries are all flammable and depending on the flash point, they can generate an explosive atmosphere already at room temperature. The environment in which oil treatment equipment is located is normally considered to be an area at risk of explosion. For metallurgical and electrical production is used carbon coke, highly flammable organic material and there are many waste processing of combustible powder.



**SECTOR G: FURNITURE, CARPENTRY, LEATHER PROCESSING,
TANNERIES, TEXTILES (Dust)**

// COMPANIES

Production kitchens, furniture production in wood, wood processing, plywood, wood chipboard, window and door production. Footwear, leather goods, textiles.

// HAZARDOUS AREAS

Wood dusts are produced in wood processing operations which can form explosive powder/air mixtures. Presence on the walls, over time, of micro dust layers and accumulation in interstices and chambers of automatic machinery. Smoothing powders may present an explosive as well as inhalation risk.

// MATERIALS

Wood flour, wood (50% pear, 50% hazelnut), wood (beech), wood (pear), wood sawdust, cork, cellulose (93% sweet wood, 6% hard wood), fine powders skin, fibers.



**SECTOR H:
PLASTICS AND RUBBER (Dust)**

// COMPANIES

Plastic and rubber processing.

// HAZARDOUS AREAS

Explosive powders may form during transport and storage of plastic or rubber granulate in mills, deposit systems and dust separation. Some tyres are made with flammable liquid solutions.

// MATERIALS

Vinyl chloride polymer, micro plastic powder.

**SECTOR L:
PAPER MILLS (Dust)**

// COMPANIES

The production of paper.

// HAZARDOUS AREAS

In paper processing operations, during the production cycle, in particular during loading, cutting and general processing, accumulations of potentially explosive dust are created.

// MATERIALS

Micro paper powder, cellulose, metal.



EXAMPLES OF EXPLOSIVE ATMOSPHERES

**SECTOR I:
EXPLOSIVES WASTE DISPOSAL
(Dust - Gas)**

// COMPANIES

Landfills, domestic shooting, automotive.

// HAZARDOUS AREAS

Production and storage of rockets, smoke, and cartridges. In sewage treatment at sewage treatment plants, the resulting biogas may form explosive gas/air mixtures. Microcarics for security systems such as Air Bag or similar. Dust disposal, dynamites, detonators, artifacts and security ammunition.

// MATERIALS

Explosive or metal powders, organic or chemical gases.

EXPLOSIVE GAS ATMOSPHERES

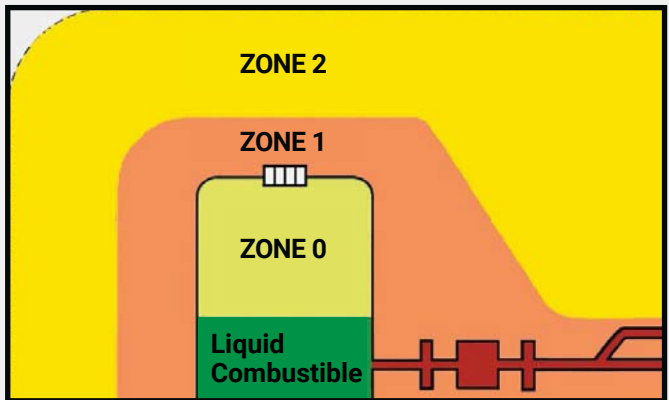

EXPLOSIVE DUST ATMOSPHERES

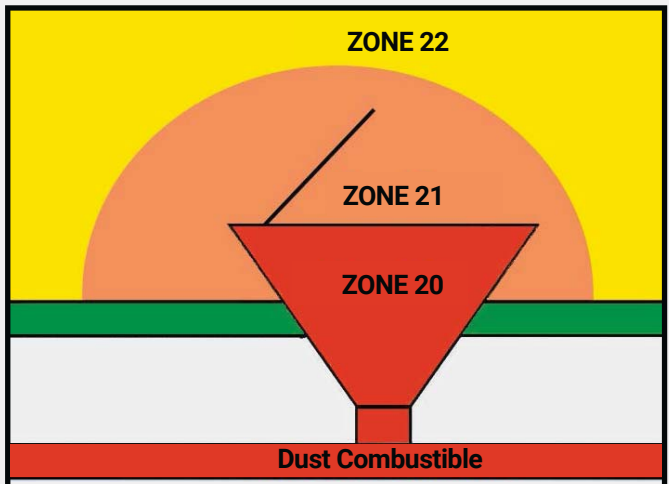

MARKING

Classification and labelling of explosion proof areas					
Flammable medium	Hazardous locations Probability of a potential atmospheres occurring	Classification of explosion proof areas	Product classification		Equipment protection level (EPL)
			Product group	Product category	
Gases, Vapours, Mists	Always, temporarily or often present	Zone 0	II		
	Occasionally present	Zone 1	II	1G	Ga Gb
	Very seldom or only present for a short period	Zone 2	II		2G 3G
Dusts	Always, temporarily or often present	Zone 20	II		
	Occasionally present	Zone 21	II	1D	Da Db
	Does not occur or only seldom for a short period	Zone 22	II		2D 3D

Classification of areas						
Explosion group	Gases and Dusts					
	IIA	IIB	IIC	Ammoniak Methan Ethan Propan	Ethylalcohol Cyclohexene n-Butane	Petrol Diesel fuel Fuel oil n-Hexane
City gas Acrylic nitrile				Ethylene Ethylenoxyd	Ethylglycol Carbon hydrogen	Ethylether
Hydrogen				Acetylene		Carbon disulphide

Temperature class
T1 < 450°C
T2 < 300°C
T3 < 200°C
T4 < 135°C
T5 < 100°C
T6 < 85°C

Product use depending on temperature class (T1 - T6). The temperature class indicates the max temperature of the exposed surface of the product. As dust explosion proof is the max surface temperature direct shown (e.g. T80°C).

Notification Body which issues QAN		
Country (example)	Code Number	Institute Notified Body (NB)
Italy	0051	IMQ

Example: **CE** **0051** **II 2G Ex d IIC T6 Gb** **NB 12 ATEX 1007 X**

II 2D Ex tb IIIC T80°C Db

Code	Dusts classification
IIIA	flammable fibres
IIB	non conductive dusts
IIC	conductive dusts

Protection principle	Type of protection	Code	Symbol	To use in zone	EN 60079-31
Prevents transmission of the explosion outside	flameproof enclosure	Ex d		1 - 2	EN 60079-1
Prevents high temperatures and sparks	increased safety	Ex e		1 - 2	EN 60079-7
Low current/voltage supply	intrinsic safety	Ex i ¹		0 - 1 - 2 20 - 21 - 22	EN 60079-11
Positive pressure device	pressurised apparatus	Ex p		1 - 2 21 - 22	EN 60079-2
Encapsulates	moulding	Ex m ³		0 - 1 - 2 20 - 21 - 22	EN 60079-18
Parts immersed in oil to isolate from explosive atmospheres	oil immersion	Ex o		1 - 2	EN 60079-6
Prevents transmission of the explosion outside	powder filling	Ex q		1 - 2	EN 60079-5
As above, but for use in Zone 2	protection "n"	Ex n		2	EN 60079-15
Dust Explosion Proof	protection "td"	Ex t ⁵		20 - 21 - 22	EN 60079-31

IP	Protection against solids/dusts	Protection against water
8	-	protected against long period of immersion
7	-	protected against the effects of temporary immersion
6	totally protected against dust	protected against strong jets of water
5	protected against dust - limited ingress	protected against low pressure jets from all directions
4	protected against solid objects > 1 mm	protected against sprays from all directions
3	protected against solid objects > 2,5 mm	protected against direct sprays up to 60° from vertical
2	protected against solid objects > 12,5 mm	protected against direct sprays up to 15° from vertical
1	protected against solid objects > 50 mm	protected against vertical falling drops of water
0	no protection	no protection

Limitations	Code
For common use	-
For use under special circumstances	X
This product is an Ex-certified component for use in a complete system	U

¹ ia (zone 0, 1, 2, 20, 21, 22) - ib (zone 1, 2, 21, 22) - ic (zone 2, 22)
³ ma (zone 0, 1, 2, 20, 21, 22) - mb (zone 1, 2, 21, 22) - mc (zone 2, 22)

⁵ ta (zone 0,1,2) - tb (zone 1,2) - tc (zone 2)
⁶ Highest possible application areas

Directive: ATEX 2014/34/EU



GIOVENZANA
INTERNATIONAL B.V.



HAZARDOUS LOCATION SOLUTIONS



GIOVENZANA SAFETY DEVICES

New Solutions for operating in explosive atmospheres
and hazardous areas.

ATEX & IECEx PRODUCTS INDEX

REGOLUS EX SWITCH DISCONNECTORS
SE and SQ Series



page 10

REGOLUS EX ENCLOSURES



page 12

ROTARY GEAR LIMIT SWITCHES
FGR2-Ex Series



page 14

MICRO SWITCHES
MFI-Ex Series



page 16



FEESTON SYSTEM EX
30, 41 Series

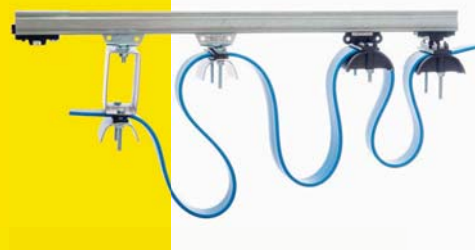

page 19



PHOENIX EX CAM SWITCHES
P0, PX, C0, CX Series



page 22



ATEX & IECEX: REGOLUS EX SWITCH DISCONNECTORS - SQ, SE SERIES
Equipment for potentially explosive atmospheres

| II 2D Ex tb IIIC T85°C Db | Zone 21-22 (Dust) | Tamb = -20°C /+55°C | IP65 |

MARKING "EX t"
STANDARD IEC 60079-31
ZONE 21, 22

The type of protection "Ex t" is based on the protection of a sealed enclosure against dust penetration and limits the surface temperature. Electrical components that could trigger an explosive atmosphere (high temperatures, sparks, etc.) are located inside IP6X-rated containers; in zone 22 with non-conductive dust, IP5X protection is permitted.

In addition, the temperature of the outer surface of the equipment is kept below the maximum surface temperature T, depending on the maximum temperature for the TCL cloud and the layer TI expected in the installation site.
IP protection complies with IEC 60079-0.

The new Regolus Ex control and emergency switches in aluminium housing, painted in RAL 7035 grey and PANTONE 102C yellow, are suitable for use in zone 21 and 22 (Dust) with nominal currents of 25-32-40-63-80-100A.

STANDARDS OF REFERENCE

EN 80079-34, EN 60947-3, EN 61241-0, EN 60079-0, EN 60079-31.

DIRECTIVE

ATEX 2014/34/EU. EAC TR TS 012/2011 "Safety components and equipment for hazardous areas and potentially explosive atmospheres".

CLASSIFICATION AREA "DUST"

Zone 21: an area in which the explosive atmosphere, in the form of a cloud of combustible dust in the air, is likely to occur during normal operations.

Zone 22: an area in which an the explosive atmosphere, in the form of a cloud of combustible dust in the air, is probably not present during normal operations but, if it does, persists only for a short time.

TYPE OF PROTECTION

Protection by enclosures (Ex "tb").



MARKING

Ex ta/tb/tc Da/Db/Dc II 1/2/3 D in accordance with IEC 60079-0, IEC 60079-31.

PRINCIPLE

The housing joint shall be hermetically sealed with special seals so that the fuel dust cannot enter. The temperature of the outer surface is limited.

DESIGN PARAMETERS

- Minimum degree of protection in accordance with IEC/EN 60529 \geq IP 6X.
- Assessment of surface dust accumulation and reduction of permitted surface temperature with \geq 5 mm dust layer.

APPLICATIONS

Various equipment that during normal scintillation operation, generate electric arcs or have very hot surfaces or any industrial controller that by this type of protection can be used in potential areas with explosive atmosphere.

ELECTRICAL SCHEMES

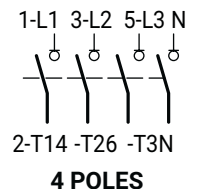
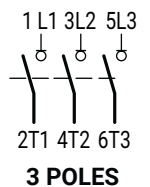

MARKING AND APPROVALS



	PRODUCT CODE	POLES NUMBER	ENCLOSURE	lth (A)	lthe (A)	AC 21A/690V (A)	AC 22A/690V (A)	AC 23A/400V (A)
SQ SERIES	SQ025003DEX09	3P	EX09 Grey	32	32	32	25	25
	SQ025003DEX10	3P	EX10 Yellow	32	32	32	25	25
	SQ032003DEX09	3P	EX09 Grey	40	40	40	32	32
	SQ032003DEX10	3P	EX10 Yellow	40	40	40	32	32
	SQ040003DEXB9	3P	EXB9 Grey	63	63	63	63	50
	SQ040003DEXB0	3P	EX10 Yellow	63	63	63	63	50
	SQ063003DEXB9	3P	EXB9 Grey	80	80	80	80	75
SQ063003DEXB0	3P	EX10 Yellow	80	80	80	80	75	

	PRODUCT CODE	POLES NUMBER	ENCLOSURE	lth (A)	lthe (A)	AC 21A/690V (A)	AC 22A/690V (A)	AC 23A/400V (A)
SE SERIES	SE630003BEXB9	3P	EXB9 Grey	63	63	63	63	50
	SE630004BEXB9	4P	EXB9 Grey	63	63	63	63	50
	SE630003BEXB0	3P	EX10 Yellow	63	63	63	63	50
	SE630004BEXB0	4P	EX10 Yellow	63	63	63	63	50
	SE800003BEXB9	3P	EXB9 Grey	86	80	80	80	60
	SE800004BEXB9	4P	EXB9 Grey	86	80	80	80	60
	SE800003BEXB0	3P	EX10 Yellow	86	80	80	80	60
	SE800004BEXB0	4P	EX10 Yellow	86	80	80	80	60
	SE100003BEXB9	3P	EXB9 Grey	100	86	100	86	67
	SE100004BEXB9	4P	EXB9 Grey	100	86	100	86	67
	SE100003BEXB0	3P	EX10 Yellow	100	86	100	86	67
	SE100004BEXB0	4P	EX10 Yellow	100	86	100	86	67

* SQ Series can be supplied with added contact blocks on request.

DIMENSIONAL DRAWINGS

SQ 025-032

Nr 2 holes for cable gland M25
Nr 2 holes for cable gland M20

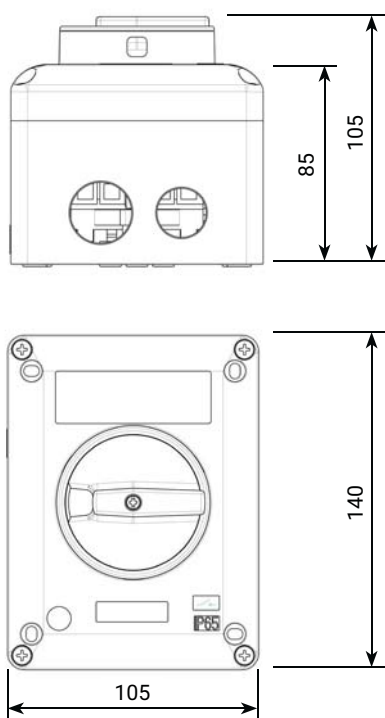

SQ 040-063 AND SE 63-80-100

Nr 2 holes for cable gland M40

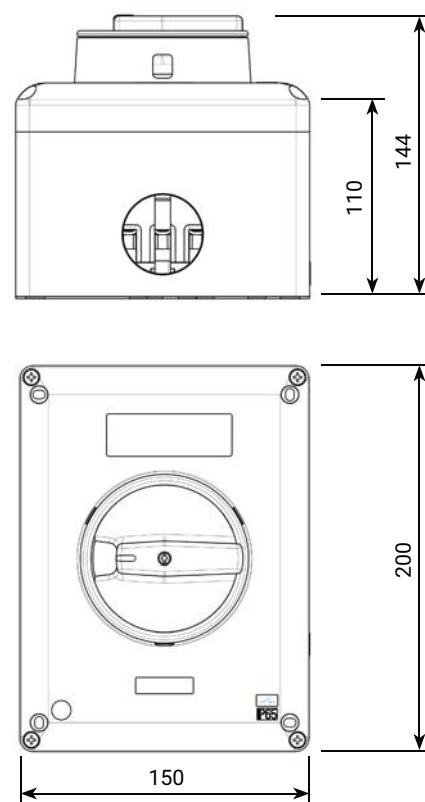



ATEX & IECEx: REGOLUS EX ENCLOSURES
Equipment for potentially explosive atmospheres

| II 2G Ex e IIC Gb - II 2D Ex tb IIIC Db | Zone 1-2-21-22 (Gas & Dust) | Tamb = -60°C /+150°C | IP65 |

The new Regolus Ex enclosures are made of aluminium alloy for use in explosion-hazard environments in accordance with the ATEX Directive 2014/34/EU.

The enclosures are to be considered components. The components require a subsequent certification/declaration by the end user.

The cover is fixed to the bottom with stainless steel screws, the seal is guaranteed by a silicone seal that allows to maintain a degree of protection IP65. The enclosures are supplied in different versions depending on the size (and therefore the maximum dissipable power) and the different colouring.

The ATEX mark (explosive atmospheres) refers to the European directive on the risk of deflagration in potentially explosive atmospheres.

CLASSIFICATION AREA "GAS"

Zone 1: an area in which an explosive atmosphere consisting of a mixture of air and flammable substances in the form of gas, vapour or mist, is likely to occur during normal operation.

Zone 2: an area in which an explosive atmosphere consisting of a mixture of air and flammable substances in the form of gas, vapour or mist, is not likely to occur during normal operations, but if it does, it will only persist for a short period.

CLASSIFICATION AREA "DUST"

Zone 21: an area in which the explosive atmosphere, in the form of a cloud of combustible dust in the air, is likely to occur during normal operations.

Zone 22: an area in which an the explosive atmosphere, in the form of a cloud of combustible dust in the air, is probably not present during normal operations but, if it does, persists only for a short time.

TYPE OF PROTECTION

Increased safety (Ex "e").
Protection by enclosures (Ex "tb").

MARKING

Ex e Gb II 2G - Ex tb IIIC Db in accordance with IEC 60079-0, IEC 60079-31, IEC 60079-7.

PRINCIPLE

Additional measures shall be applied to provide increased safety against the



possibility that the construction will not produce excessive arcs, sparks or temperatures during normal operation or under specified abnormal conditions.



DESIGN PARAMETERS

- For live parts, not insulated, special protection requirements shall apply.
- A minimum degree of protection (IP code) of enclosure is required. The purpose of the degree of protection is to prevent the penetration of solids or water (conductors) which may affect the insulation distances, which guarantee the maintenance of the non-sparking property.
- For windings, mechanical and insulation resistances, higher requirements apply and the windings must be protected from an increase in temperature.
- Minimum sections are provided for cable winding, impregnation and strengthening of coils and for thermal monitoring equipment.



APPLICATIONS

Installation equipment such as junction boxes, connection panels for heating systems, batteries, transformers, reactors and engines.

MARKING AND APPROVALS



PRODUCT CODE	OVERALL DIMENSIONS	FINISHING COLOR COVER/BOTTOM
BNA/8NGEX	150x200x110mm	Grey/Black
BNA/8NYEX	150x200x110mm	Yellow/Black
BNB/8NGEX	105x140x85mm	Grey/Black
BNB/8NYEX	105x140x85mm	Yellow/Black

DIMENSIONAL DRAWINGS

BNB SERIES

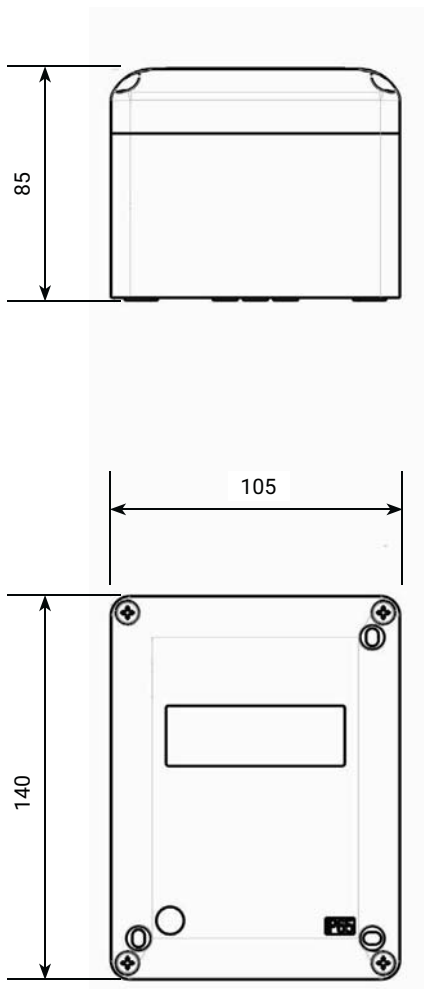

BNA SERIES

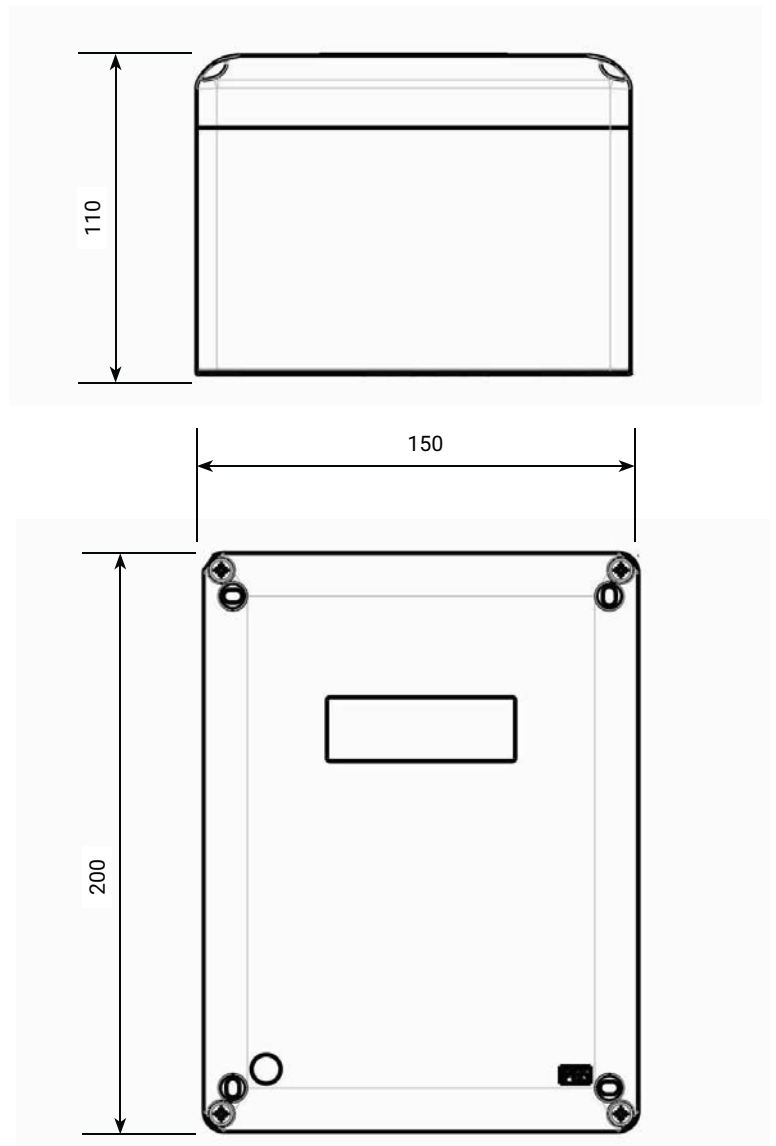



ATEX & IECEx: ROTARY GEAR LIMIT SWITCHES - FGR2-Ex Series
Equipment for potentially explosive atmospheres. Single single or rear twin shaft, with 4 or 6 microswitches and transmission ratio from 012 to 200.

| II 3G Ex dc ec IIB T5 Gc | II 2D Ex tb IIIC T85°C Db | Zone 2-21 (Gas & Dust) | Tamb = -20°C/+70°C | IP65 |

The innovative FGR2-Ex limit switch, ATEX and IECEx certified, in aluminium and antistatic plastic housing, suitable for use in zone 2 (Gas) and zone 21 (Dust).

The apparatus, through a gear transmission, controls a cam system operating on 4 or 6 micro switches that after a certain number of revolutions predispose the engine or the equipment at the start or stop. Each cam is equipped with a micrometric "adjustable register screw" which operates independently, so it is possible to calibrate the opening and closing of each micro switch according to the necessary functional requirements. The gear transmission system allows you to choose different ratios and can also be supplied in a twin rear shaft version.

STANDARDS OF REFERENCE

EN 80079-34, EN 60947-3, EN 61241-0, EN 60079-0, EN 60079-31, EN 60079-1, EN 60079-7.

DIRECTIVE

ATEX 2014/34/EU. EAC TR TS 012/2011 "Safety components and equipment for hazardous areas and potentially explosive atmospheres".

CLASSIFICATION AREA "GAS & DUST"

Zone 2: an area in which an explosive atmosphere consisting of a mixture of air and flammable substances in the form of gas, vapour or mist, is not likely to occur during normal operations, but if it does, it will only persist for a short period.

Zone 21: an area in which the explosive atmosphere, in the form of a cloud of combustible dust in the air, is likely to occur during normal operations.

TYPE OF GAS PROTECTION

Limited breathing housing (Ex "dc ec").

MARKING

II 3G Ex dc ec IIB T5 Gc in accordance with IEC 60079-0, IEC 60079-1, IEC 60079-7.

PRINCIPLE

Limited in the power dissipation (ΔT limited), so that the depression that occurs when de-energized is such as to delay the entry of explosive atmosphere for a time limit indicated by the norm.

TYPE OF DUST PROTECTION

Protection by enclosure (Ex "tb").

MARKING

II 2D Ex tb IIIC T 85°C Db in accordance with IEC 60079-0, IEC 60079-31.

PRINCIPLE

The housing joint shall be hermetically sealed with special seals so that the fuel dust cannot enter. The temperature of the outer surface is limited.

APPLICATIONS

For the control of revolving parts of industrial or construction machinery such as rope reel drums, operating machines, sliders, cranes, etc.

The type of housing designed and the internal components adopted, make this equipment for use in potential areas with explosive atmosphere for both gas and dust according to ATEX Directive 2014/34/EU.



MARKING AND APPROVALS



GENERAL CHARACTERISTICS

Case	Housing made of aluminium Anti-static plastic cover
Ratio	012 - 033 - 050 - 100 - 200
Protection Class	IP65
Shaft Type	Steel mounted on ball bearings Available version with coaxial shaft
Fixing Type	Bottom with stainless steel screws Front (flanged with FLG accessories)
Micro Switches	MFI-Ex Series Directive ATEX 2014/34/EU
Micro Switches	Max nr 6 - micrometric adjustment
Cam Block	Self-lubricating and transparent support for easy cam display
Cable Entry	M16 (max nr 2) not included
Options	15 pinions
Rated operational current	8A (1A)
Ambient Temperature	-20°C ... +70°C

RATIO	SINGLE SHAFT	REAR SHAFT
-------	--------------	------------



4 Micro Switches	6 Micro Switches	4 Micro Switches	6 Micro Switches
------------------	------------------	------------------	------------------



012	FGR2006EX	FGR20066EX	FGR2006BEX	FGR2006B6EX
033	FGR2007EX	FGR20076EX	FGR2007BEX	FGR2007B6EX
050	FGR2008EX	FGR20086EX	FGR2008BEX	FGR2008B6EX
100	FGR2009EX	FGR20096EX	FGR2009BEX	FGR2009B6EX
200	FGR2010EX	FGR20106EX	FGR2010BEX	FGR2010B6EX

DIMENSIONAL DRAWINGS

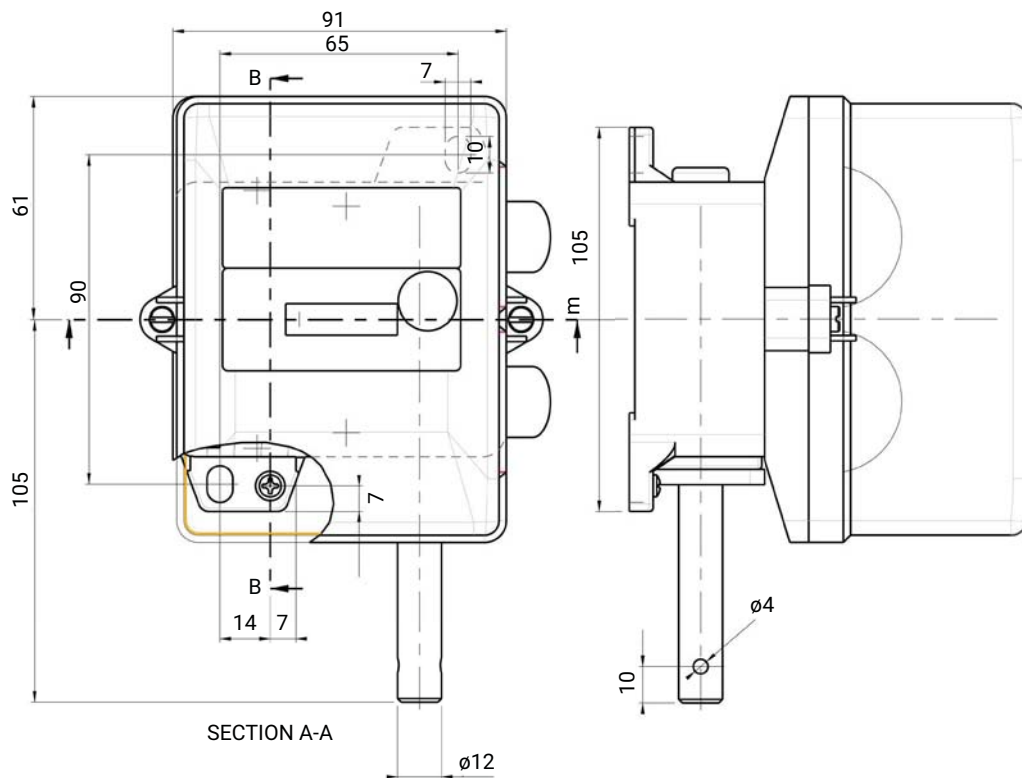



ATEX & IECEx: MICRO SWITCHES - MFI-Ex SERIES
Equipment for potentially explosive atmospheres, available in 9 drive types.

| II 3G Ex dc ec IIB Gc | Zone 2 (Gas) |

New ATEX and IECEx certified MFI-Ex micro switches for use in zone 2 (Gas).

Micro NC switches with positive opening, with high reliability snap-action operation, equipped with self-cleaning silver alloy switch contacts and available with pin plunger or different types of actuator lever.

STANDARDS OF REFERENCE

EN 80079-34, EN 60947-3, EN 61241-0,
EN 60079-0, EN 60079-31, EN 60079-1,
EN 60079-7.

DIRECTIVE

ATEX 2014/34/EU. EAC TR TS 012/2011
"Safety components and equipment for hazardous areas and potentially explosive atmospheres".

CLASSIFICATION AREA "GAS"

Zone 2: an area in which an explosive atmosphere consisting of a mixture of air and flammable substances in the form of gas, vapour or mist, is not likely to occur during normal operations, but if it does, it will only persist for a short period.

TYPE OF GAS PROTECTION

Restricted breathing case (Ex "dc ec").

MARKING

II 3G Ex dc ec IIB Gc in according with IEC 60079-0, IEC 60079-1, IEC 60079-7.

PRINCIPLE

Limited power dissipation (ΔT limited), so the depression that is created when de-energized, is such as to delay the entry of explosive atmosphere for a time limit specified by the standard.

APPLICATIONS

ATEX and IECEx micro switches are used in many fields such as: control valves, actuators, conveyor belts, materials handling and in petrochemical plants in general.

The type of materials and the internal design of the elements, conform this component for use in potential areas with explosive atmospheres due to the presence of gas according to ATEX Directive 2014/34/EU.



GENERAL CHARACTERISTICS

According to	IEC / EN 61058 UL1054	
Working Temperature	-20 ... +89 only for North America -36 ... +126	°C °F
Mechanical life	1 x 10 ⁶	cycles/min
Electrical life	5 x 10 ⁵	cycles/min
Termination type	Screw terminal	

ELECTRICAL CHARACTERISTICS

Rated thermal current I_{th}	8	A
Rated insulated voltage U_i	250	V
Rated impulse withstand voltage U_{imp}	1500	V
Rated operating current I_e	8 - 250 - Resistive load 1 - 250 - Inductive load	A - V A - V
Electric shock protection	Class II	
Pollution Class	2	

MARKING & APPROVALS



DIMENSIONAL DRAWINGS

Micro switches with Screw terminals



1 NC - 1 NO
SNAP ACTION

MFI.Ex

Pin Plunger

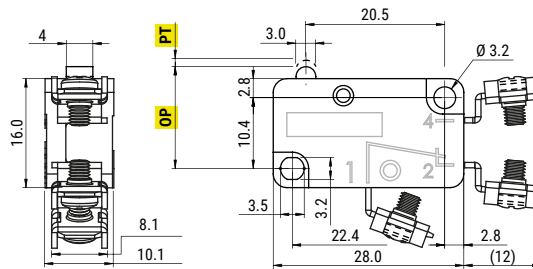

OF	max 5.1	N
RF	min 1.9	N
PT	max 1.4	mm
OT	min 0.8	mm
OP	14.4 ±0.5 mm	

MFI.1Ex

Long roller lever

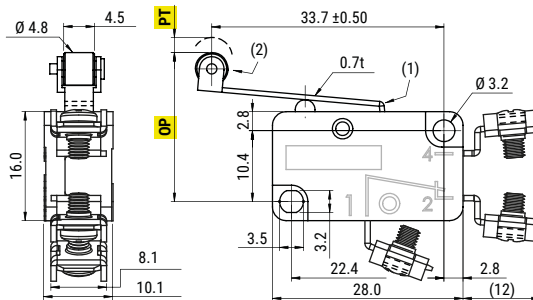

OF	max 3.2	N
RF	min 1.0	N
PT	max 3.3	mm
OT	min 0.8	mm
OP	20.3 ±1.2 mm	

(1) Lever in stainless steel
(2) Roller in plastic

MFI.2Ex

Simulated roller lever

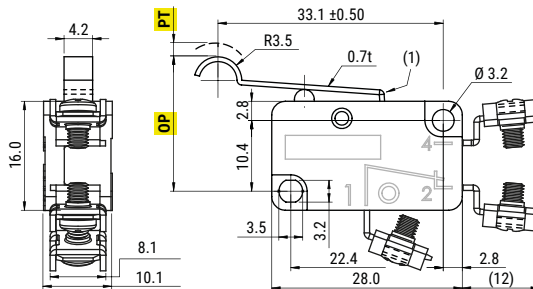

OF	max 3.2	N
RF	min 1.0	N
PT	max 3.3	mm
OT	min 0.8	mm
OP	18.4 ±1.2 mm	

(1) Lever in stainless steel

MFI.3Ex

Roller lever

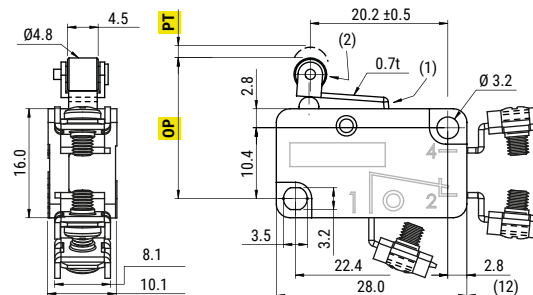

OF	max 5.1	N
RF	min 1.9	N
PT	max 1.4	mm
OT	min 0.6	mm
OP	20.3 ±0.8 mm	

(1) Lever in stainless steel
(2) Roller in plastic

MFI.4Ex

Long lever

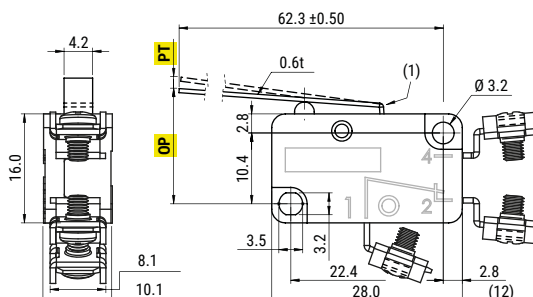

OF	max 1.3	N
RF	min 0.15	N
PT	max 7.6	mm
OT	min 2.2	mm
OP	15.1 ±2.6 mm	

(1) Lever in stainless steel

DIMENSIONAL DRAWINGS

**Micro switches with
Screw terminals**



1 NC - 1 NO
SNAP ACTION

MFI.5Ex

Lever

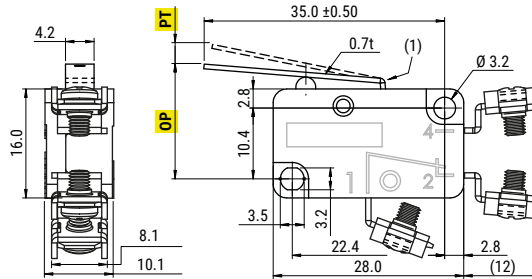

OF	max 3.2	N
RF	min 1.2	N
PT	max 3.3	mm
OT	min 0.8	mm
OP	15.1 ± 1.2	mm

(1) Lever in stainless steel

MFI.6Ex

Short lever

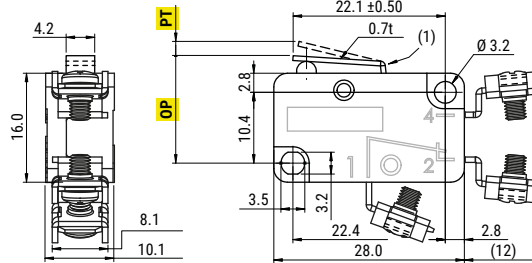

OF	max 5.1	N
RF	min 1.9	N
PT	max 1.6	mm
OT	min 0.6	mm
OP	15.1 ± 0.6	mm

(1) Lever in stainless steel

MFI.7Ex

Roller lever L = 16 mm

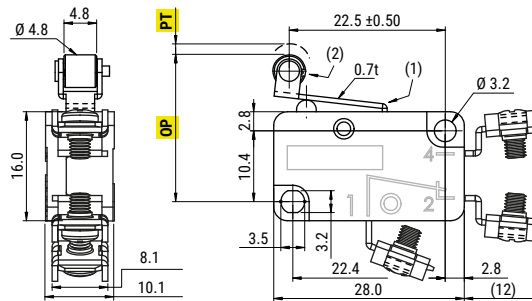

OF	max 4.5	N
RF	min 1.9	N
PT	max 1.8	mm
OT	min 0.8	mm
OP	21.1 ± 0.6	mm

(1) Lever in stainless steel

(2) Roller in plastic

MFI.8Ex

Pin plunger 90°

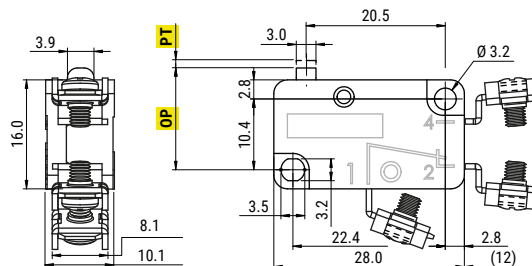

OF	max 5.1	N
RF	min 1.9	N
PT	max 1.4	mm
OT	min 0.8	mm
OP	14.4 ± 0.5	mm



ATEX & IECEx: FEESTON SYSTEM Ex

Equipment for potentially explosive atmospheres.

| II 2G Ex h IIB T5 Gb | II 2D Ex h IIIC T90° Db | Zone 1-2 (Gas) e 21-22 (Dust) | Tamb = -25°C /+80°C |

New Feeston System Ex series 30 and 41 certified ATEX and IECEx for use in potentially explosive areas.

STANDARDS OF REFERENCE
EN 80079-36, ISO IEC 80079-36.

DIRECTIVE
ATEX 2014/34/EU. EAC TR TS 012/2011 "Safety components and equipment for hazardous areas and potentially explosive atmospheres".

The Feeston System is the traditional system for the transmission of energy by cable. The main applications of this system are mobile energy consumers such as cranes, monorails, electric hoists, machine tools, car wash systems, plating lines, etc.

One of the most successful is the crane where the festoon line transmits the signals to control the movements of the winch. The 30 and 41 lines are composed of a "C" bar fixed along the crane's axis of movement. The cable is supported by trolleys that slide hanging from the bar to "C".

This feeding system has several advantages:

- Safety: the cables are flame resistant, the conductors are completely protected;
- Versatility: can be used for straight tracks such as curved tracks, for internal and external applications;
- Easy to install;
- Line maintenance is extremely low.

Both lines 30 and 41 offer a complete selection of articles and accessories to customize the line according to customer specifications. ATEX and iecex certifications allow the use of this system in hazardous areas with potentially explosive atmospheres.

CLASSIFICATION AREA "GAS"

Zone 1: an area in which an explosive atmosphere consisting of a mixture of air and flammable substances in the form of gas, vapour or mist, is likely to occur during normal operation.

Zone 2: an area in which an explosive atmosphere consisting of a mixture of air and flammable substances in the form of gas, vapour or mist, is not likely to occur during normal operations, but if it does, it will only persist for a short period.

CLASSIFICATION AREA "DUST"

Zone 21: an area in which the explosive atmosphere, in the form of a cloud of combustible dust in the air, is likely to occur during normal operations.

Zone 22: an area in which an the explosive atmosphere, in the form of a cloud of

combustible dust in the air, is probably not present during normal operations but, if it does, persists only for a short time.

MARKING

II 2G Ex h IIB T5 Gb
II 2D Ex h IIIC T90° Db

APPLICATIONS

To use in hazardous areas with potentially explosive atmospheres.

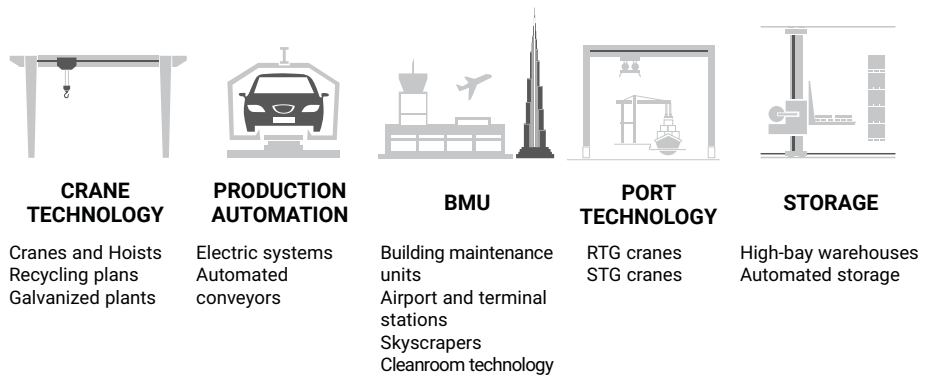

PRODUCT LINES AVAILABLE

- 30 Ex Series
- 41 Ex Series

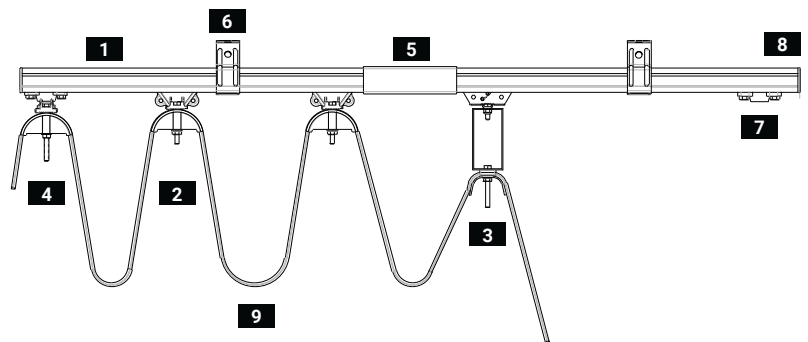

1 C-RAIL BAR	In galvanized steel
2 TROLLEY	Supports the cable
3 TOWING TROLLEY	Connects to the mobile device and allows the movement
4 HEAD CLAMP	Cable-supporting element without movement
5 JOINT	Connects two C-rail bars
6 SUPPORT	Holds the C-rail bar
7 END STOP	Prevents the exit of the trolley from the C-rail bar
8 END CAP	Closes and protects the C-rail bar
9 CABLE	Transmits the energy

MARKING & APPROVALS



For more informations, contact our Technical Support.
customerstechnicalsupport@giovenzana.com

C-RAIL BAR

SERIES	CHARACTERISTICS		
	BAR HEIGHT	LOAD CAPACITY	MATERIAL
30 Ex SERIES	30 mm	100 kg/m	Galvanized steel
41 Ex SERIES	41 mm	140 kg/m	Galvanized steel



MODULES AVAILABLE	
STRAIGHT	4 meters module
CURVE	90° curve radius 1,5 meters (only for line 41)



30 Ex SERIES





PRODUCT	CODE	DESCRIPTION
	30607001	C-Rail Bar Length: 4 meters
	30607002	Joint
	30607003	Track support bracket
	30607017	Track support bracket - ceiling fixing
	30607004	Support arm bracket - bracket fixing
	30607015	End cap
	30607016	Cable clamp
	30607005Ex	End stop

PRODUCT	CODE	DESCRIPTION
	30607007Ex	Towing trolley
	30607010Ex	Flat cable trolley - Material: steel - Saddle: 68 mm
	30607011Ex	Flat cable trolley - Material: PA - Saddle: 55 mm
	30607021Ex	Round cable trolley
	30607020Ex	Head clamp - Saddle: 55 mm
	30607006Ex	Head clamp - Saddle: 76 mm



41 Ex SERIES

PRODUCT	CODE	DESCRIPTION
	30602001/4	C-Rail Bar Lenght: 4 meters
	30602002	Single joint
	30602034	Double joint
	30602003	Track support bracket
	30602004	Track support bracket - ceiling fixing
	30602038Ex	End stop

PRODUCT	CODE	DESCRIPTION
	30602091Ex	Single towing trolley
	30602020Ex	Double towing trolley
	30602086Ex	Flat cable trolley - Material: steel - Saddle: 68 mm
	30602071Ex	Head clamp - Saddle: 55 mm
	30602072Ex	Head clamp - Saddle: 76 mm



ATEX & IECEx: PHOENIX Ex CAM SWITCHES
Equipment for potentially explosive atmospheres.

| II 2D Ex tb IIIC T85°C Db | Zone 21-22 (Dust) | Tamb = -20°C /+55°C | IP65 |

The new ATEX and IECEx control cam switches in aluminium housing, painted in RAL 7035 grey and yellow 102C PANTONE, are suitable for use in zone 21 and 22 (Dust) with nominal currents from 12 to 40A.

STANDARDS OF REFERENCE

EN 80079-34, EN 60947-3, EN 60079-0, EN 60079-31.

DIRECTIVE

ATEX 2014/34/EU.

CLASSIFICATION AREA "DUST"

Zone 21: an area in which the explosive atmosphere, in the form of a cloud of combustible dust in the air, is likely to occur during normal operations.

Zone 22: an area in which an the explosive atmosphere, in the form of a cloud of combustible dust in the air, is probably not present during normal operations but, if it does, persists only for a short time.

TYPE OF PROTECTION

Protection by enclosures (Ex "tb").

MARKING

Ex ta/tb/tc Da/Db/Dc II 1/2/3 D in accordance with IEC 60079-0, IEC 60079-31.

PRINCIPLE

The housing joint shall be hermetically sealed with special seals so that the fuel dust cannot enter. The temperature of the outer surface is limited.

DESIGN PARAMETERS

- Minimum degree of protection in accordance with IEC/EN 60529 IP 6X.
- Assessment of surface dust accumulation and reduction of permitted surface temperature with 5 mm dust layer.

APPLICATIONS

The Cam Switches Phoenix Ex series, can be involved in different application, from automation industry to food machines (professional coffee machines, pasta production, bottling machines, ...) passing through the supply of engines, use in distribution switchboards and controls for professional welders.



PRODUCT LINES AVAILABLE

- PO & PX series from 12A, 16A and 20A (maximum 3 wafers)
- CO & CX series from 25A, 32A, 40A (maximum 2 wafers)

By request it is possible to supply special electrical configurations (for example: electric closures, n° of positions, switching angles, etc.)

For more informations, contact our technical support.

customerstechnicalsupport@giovenzana.com

DIMENSIONAL DRAWINGS

PO & PX / CO & CX

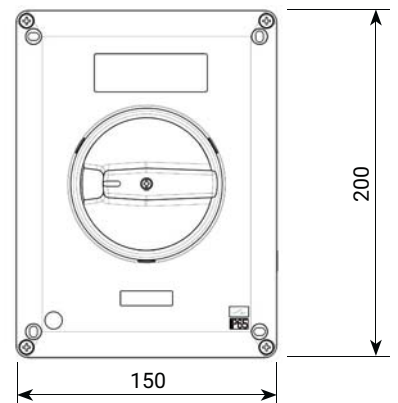
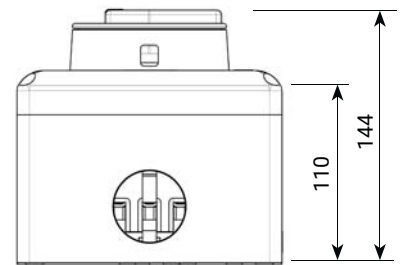

Nr 2 holes for cable gland M40

MARKING & APPROVALS



ORDER FORM FOR SPECIAL SCHEMES ON REQUEST

- For P0 - PX Series the maximum poles number is 6 (3 wafers).
- For C0 - CX Series the maximum poles number is 4 (2 wafers).
- Padlockable only in position 0/OFF (max 3 padlocks).

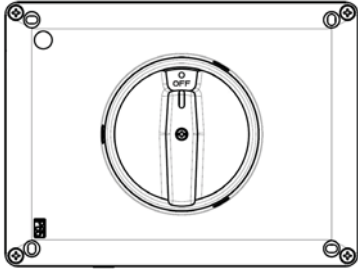

HORIZONTAL position with 0/OFF at 0°

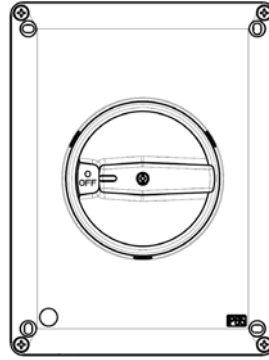

VERTICAL position with 0/OFF at -90°

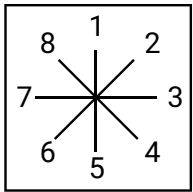

45 90

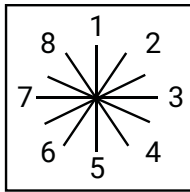

30 60

POSITION	DESCRIPTION	POSITION	DESCRIPTION
1		7	
2		8	
3		9	
4		10	
5		11	
6		12	

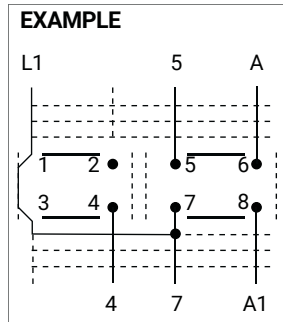
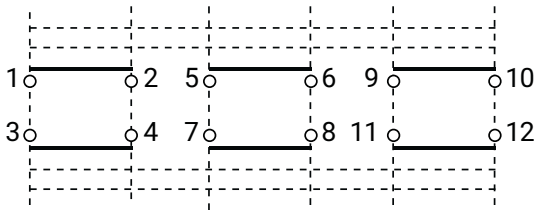

	CATEGORY	AMP/kW	VOLT
Rate current Ie	<input type="checkbox"/> AC-21A	A	V
	<input type="checkbox"/> AC-22A	A	V
Operational rated voltage Ue	<input type="checkbox"/> AC-23A	1 Ph kW	V
		3Ph kW	V
	<input type="checkbox"/> AC-3	1 Ph kW	V
		3Ph kW	V

Series

Actuator Grey cover / Black knob (B9)
 Yellow cover / Black knob (B0)

Notes

Company

Contact person Phone:
 E-mail:
 Quantity:
 Due date:
 Order Nr.:

3	11-12										
	9-10										
2	7-8										
	5-6										
1	3-4										
	1-2										
WAFER	CONT.	POSITIONS									

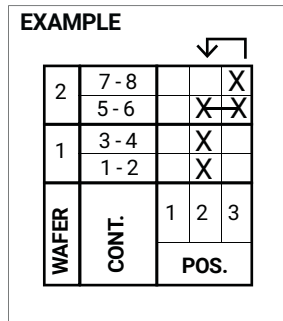

- Opened contact
- Closed contact
- Break before make
- Contact closed: no interruption during changeover
- Spring return
- Make before break
- Open contact early make



GIOVENZANA
INTERNATIONAL B.V.

GREENLAND
GREENLAND

UNITED STATES CANADA
CANADA
UNITED STATES
UNITED STATES

MEXICO
MEXICO

CUBA

BELIZE
GUATEMALA
HONDURAS
EL SALVADOR

NICARAGUA
COSTA RICA
PANAMA

DOMINIKAN REPUBLIC
HAITI

VENEZUELA
VENEZUELA

COLOMBIA
PERU
ECUADOR

BRASIL
BRASIL

BRASIL

BOLIVIA
BOLIVIA

BOLIVIA
BOLIVIA

CHILE
CHILE

CHILE
CHILE

CHILE
CHILE

CHILE
CHILE

CHILE
CHILE

CHILE
CHILE

CHILE
CHILE

CHILE
CHILE

CHILE
CHILE

CHILE
CHILE

CHILE
CHILE

CHILE
CHILE

CHILE
CHILE

CHILE
CHILE

CHILE
CHILE

CHILE
CHILE

CHILE
CHILE

CHILE
CHILE

ICELAND
IREL
MOROCCO
MAURITANIA
WESTERN SAHARA
MAURITANIA
MAURITANIA
SENEGAL
GAMBIA
GUINEA
SIERRA LEONE
LIBERIA

LOGISTIC

Giovenzana International B.V. to support the market and his different necessity has created this organization that is always in process to cover territory in five different hubs.

SALES OFFICES

GIOVENZANA INTERNATIONAL B.V.
Budapest, Hungary - Office and Delivery

G.T.R. LLC
Moscow, Russian Federation - Office and Logistic Hub

GIOVENZANA CONTROLS INDIA Pvt. Ltd.
Mumbai, India - Office

GIOVENZANA DEUTSCHLAND
Hannover, Germany - Office

GIOVENZANA do Brasil
São Paulo, Brazil - Office and Logistic Hub

Branch

GIOVENZANA INTERNATIONAL B.V.
Dubai U.A.E. - Office and Logistic Hub for ME and FE included China, India, Oceania, Africa



HEADQUARTER

GIOVENZANA INTERNATIONAL B.V.
Amsterdam, The Netherland - Industrial and Commercial

MANUFACTURER UNITS

G.G.T. Srl
Milan, Italy - Historical Unit
G.G.Space Kft
Budapest, Hungary
GIOVENZANA DO BRASIL
Guaíba, RS - Brazil

ENGINEERING

ELECTRA ENGINEERING Srl
Milan, Italy

LOGISTIC WAREHOUSES

ITALY
HUNGARY
RUSSIAN FEDERATION
DUBAI - U.A.E.
BRAZIL

GIOVENZANA INTERNATIONAL B.V.

Strawinskylaan, 1105
1077 XX Amsterdam, **THE NETHERLANDS**
Ph: +31 (0) 20.4413576
Fax: +31 (0) 20.4413456
E-mail: giovenzana@giovenzana.com

G.T.R. LLC

Likhov lane, h.3, b.2, office 101
127051, Moscow, **RUSSIAN FEDERATION**
Ph: +7.495.6991296 / +7.499.9228548
Fax: +7.495.6991520
E-mail: gtr@giovenzana.com

GIOVENZANA CONTROLS INDIA Pvt. Ltd.

A-203, Knox Plaza, Chincholi, Off Link Road
Near Mindspace, Malad West
400064 Mumbai, **INDIA**
Ph: +91.22.42640071
E-mail: ggindia@giovenzana.com

GIOVENZANA do Brasil

Rua Enxovia, 472 - cjl 314-1315 Cep. 04711-030
Vila São Francisco, São Paulo, **BRASIL**
Ph: +55 11 3360-6840 / +55 11 3530-5316
E-mail: logistic.brasil@giovenzana.com

GIOVENZANA INTERNATIONAL B.V. - Dubai Branch

Jafza 15, Jebel Ali Free Zone
P.O. Box 262146 Dubai, **U.A.E.**
Ph: +971.4.8870788
Fax: +971.4.8870787
E-mail: uae@giovenzana.com

